

TL431, TL431A, TL432, TL432A ADJUSTABLE PRECISION SHUNT REGULATORS

SLVS005W – JULY 1978 – REVISED DECEMBER 2003

- **Initial Accuracy (25°C)**
 - 1% . . . A Grade
 - 2% . . . Standard Grade
- **Equivalent Full-Range Temperature Coefficient . . . 30 ppm/°C**
- **0.2-Ω Typical Output Impedance**
- **Sink-Current Capability . . . 1 mA to 100 mA**
- **Low Output Noise**
- **Adjustable Output Voltage . . . V_{ref} to 36 V**

TL431, TL431A . . . D PACKAGE
(TOP VIEW)

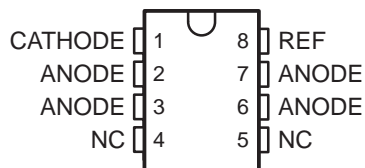

TL431, TL431A . . . P, PS, OR PW PACKAGE
(TOP VIEW)

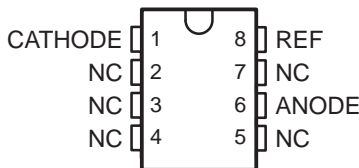

NC – No internal connection

TL431 . . . PK PACKAGE
(TOP VIEW)

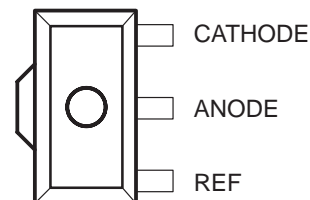

TL431, TL431A . . . LP PACKAGE
(TOP VIEW)

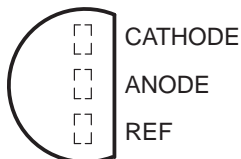

TL431, TL431A . . . DBV PACKAGE
(TOP VIEW)

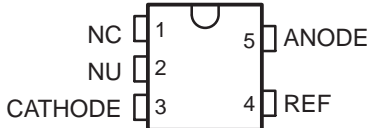

NC – No internal connection
NU – Make no external connection

TL431 . . . KTP PACKAGE
(TOP VIEW)

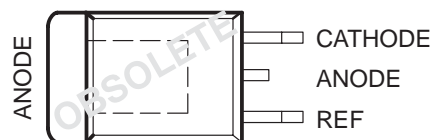

TL432, TL432A . . . DBV PACKAGE
(TOP VIEW)

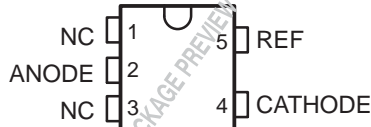

NC – No internal connection

description/ordering information

The TL431 and TL432 are three-terminal adjustable shunt regulators, with specified thermal stability over applicable automotive, commercial, and military temperature ranges. The output voltage can be set to any value between V_{ref} (approximately 2.5 V) and 36 V, with two external resistors (see Figure 17). These devices have a typical output impedance of 0.2 Ω. Active output circuitry provides a very sharp turn-on characteristic, making these devices excellent replacements for Zener diodes in many applications, such as onboard regulation, adjustable power supplies, and switching power supplies. The TL432 has exactly the same functionality and electrical specifications as the TL431, but has a different pinout for the DBV package.

The TL43xxC devices are characterized for operation from 0°C to 70°C, and the TL43xxI devices are characterized for operation from –40°C to 85°C.



Please be aware that an important notice concerning availability, standard warranty, and use in critical applications of Texas Instruments semiconductor products and disclaimers thereto appears at the end of this data sheet.

PRODUCTION DATA information is current as of publication date. Products conform to specifications per the terms of Texas Instruments standard warranty. Production processing does not necessarily include testing of all parameters.

 **TEXAS
INSTRUMENTS**

POST OFFICE BOX 655303 • DALLAS, TEXAS 75265

Copyright © 2003, Texas Instruments Incorporated

TL431, TL431A, TL432, TL432A ADJUSTABLE PRECISION SHUNT REGULATORS

SLVS005W – JULY 1978 – REVISED DECEMBER 2003

description/ordering information (continued)

TL431, TL432 ORDERING INFORMATION V_{ref} TOLERANCE (25°C) = 2%

TA	PACKAGE†		ORDERABLE PART NUMBER	TOP-SIDE MARKING‡
0°C to 70°C	PDIP (P)	Tube of 50	TL431CP	TL431CP
	SOIC (D)	Tube of 75	TL431CD	TL431C
		Reel of 2500	TL431CDR	
	SOP (PS)	Reel of 2000	TL431CPSR	T431
	SOT-23 (DBV)	Reel of 3000	TL431CDBVR	T3C_
		Reel of 250	TL431CDBVT	
		Reel of 3000	TL432CDBVR§	TBD
	SOT-89 (PK)	Reel of 1000	TL431CPK	43
	TO-226/TO-92 (LP)	Bulk of 1000	TL431CLP	TL431C
		Ammo of 2000	TL431CLPM	
		Reel of 2000	TL431CLPR	
	TSSOP (PW)	Tube of 150	TL431CPW	T431
Reel of 2000		TL431CPWR		
-40°C to 85°C	PDIP (P)	Tube of 50	TL431IP	TL431IP
	SOIC (D)	Tube of 75	TL431ID	TL431I
		Reel of 2500	TL431IDR	
	SOT-23 (DBV)	Reel of 3000	TL431IDBVR	T3I_
		Reel of 250	TL431IDBVT	
		Reel of 3000	TL432IDBVR§	TBD
	SOT-89 (PK)	Reel of 1000	TL431IPK	3I
	TO-226/TO-92 (LP)	Bulk of 1000	TL431ILP	TL431I
		Reel of 2000	TL431ILPR	

† Package drawings, standard packing quantities, thermal data, symbolization, and PCB design guidelines are available at www.ti.com/sc/package.

‡ DBV: The actual top-side marking has one additional character that designates the assembly/test site.

§ Product Preview

TL431, TL431A, TL432, TL432A ADJUSTABLE PRECISION SHUNT REGULATORS

SLVS005W – JULY 1978 – REVISED DECEMBER 2003

description/ordering information (continued)

TL431A, TL432A ORDERING INFORMATION V_{ref} TOLERANCE (25°C) = 1%

TA	PACKAGE†		ORDERABLE PART NUMBER	TOP-SIDE MARKING‡
0°C to 70°C	PDIP (P)	Tube of 50	TL431ACP	TL431ACP
	SOIC (D)	Tube of 75	TL431ACD	431AC
		Reel of 2500	TL431ACDR	
	SOP (PS)	Reel of 2000	TL431ACPSR	T431A
	SOT-23 (DBV)	Reel of 3000	TL431ACDBVR	TAC_
		Reel of 250	TL431ACDBVT	
		Reel of 3000	TL432ACDBVR§	TBD
	TO-226/TO-92 (LP)	Bulk of 1000	TL431ACLPM	TL431AC
		Ammo of 2000	TL431ACLPM	
		Reel of 2000	TL431ACLPR	
	TSSOP (PW)	Tube of 150	TL431ACPW	T431A
		Reel of 2000	TL431ACPWR	
-40°C to 85°C	PDIP (P)	Tube of 50	TL431AIP	TL431AIP
	SOIC (D)	Tube of 75	TL431AID	431AI
		Reel of 2500	TL431AIDR	
	SOT-23 (DBV)	Reel of 3000	TL431AIDBVR	TAI_
		Reel of 250	TL431AIDBVT	
		Reel of 3000	TL432AIDBVR§	TBD
	TO-226/TO-92 (LP)	Bulk of 1000	TL431AILPM	TL431AI
		Ammo of 2000	TL431AILPM	
		Reel of 2000	TL431AILPR	

† Package drawings, standard packing quantities, thermal data, symbolization, and PCB design guidelines are available at www.ti.com/sc/package.

‡ DBV: The actual top-side marking has one additional character that designates the assembly/test site.

§ Product Preview

symbol



functional block diagram

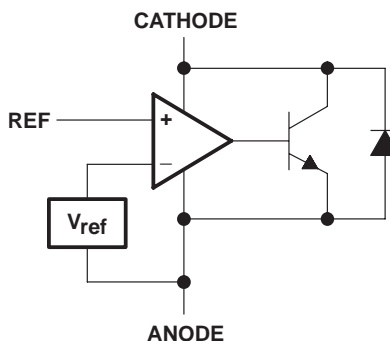

TL431, TL431A, TL432, TL432A ADJUSTABLE PRECISION SHUNT REGULATORS

SLVS005W – JULY 1978 – REVISED DECEMBER 2003

equivalent schematic†

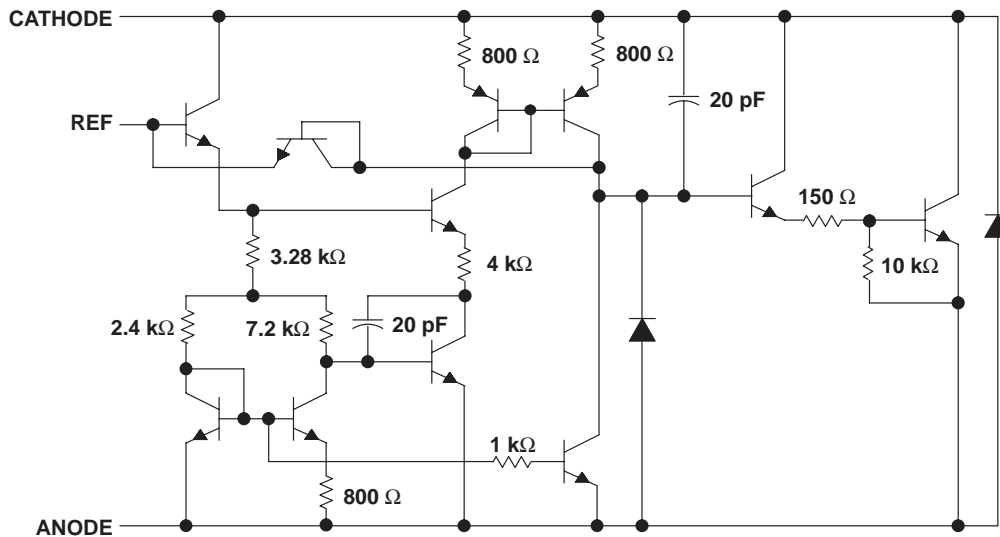

† All component values are nominal.

absolute maximum ratings over operating free-air temperature range (unless otherwise noted)‡

Cathode voltage, V_{KA} (see Note 1)	37 V
Continuous cathode current range, I_{KA}	-100 mA to 150 mA
Reference input current range	-50 μ A to 10 mA
Operating virtual junction temperature, T_J	150°C
Storage temperature range, T_{stg}	-65°C to 150°C

‡ Stresses beyond those listed under “absolute maximum ratings” may cause permanent damage to the device. These are stress ratings only, and functional operation of the device at these or any other conditions beyond those indicated under “recommended operating conditions” is not implied. Exposure to absolute-maximum-rated conditions for extended periods may affect device reliability.

NOTE 1: Voltage values are with respect to the ANODE terminal unless otherwise noted.

package thermal data (see Note 2)

PACKAGE	BOARD	θ_{JC}	θ_{JA}
PDIP (P)	High K, JESD 51-7	57°C/W	85°C/W
POWER-FLEX (KTP)	High K, JESD 51-5	19°C/W	28°C/W
SOIC (D)	High K, JESD 51-7	39°C/W	97°C/W
SOT-89 (PK)	High K, JESD 51-7	9°C/W	52°C/W
SOT-23 (DBV)	High K, JESD 51-7	131°C/W	206°C/W
TO-92 (LP)	High K, JESD 51-7	55°C/W	140°C/W
TSSOP (PW)	High K, JESD 51-7	65°C/W	149°C/W

NOTE 2: Maximum power dissipation is a function of $T_J(\text{max})$, θ_{JA} , and T_A . The maximum allowable power dissipation at any allowable ambient temperature is $P_D = (T_J(\text{max}) - T_A)/\theta_{JA}$. Operating at the absolute maximum T_J of 150°C can affect reliability.



POST OFFICE BOX 655303 • DALLAS, TEXAS 75265

TL431, TL431A, TL432, TL432A ADJUSTABLE PRECISION SHUNT REGULATORS

SLVS005W – JULY 1978 – REVISED DECEMBER 2003

recommended operating conditions

		MIN	MAX	UNIT	
V_{KA}	Cathode voltage	V_{ref}	36	V	
I_{KA}	Cathode current	1	100	mA	
T_A	Operating free-air temperature range	TL431C, TL431AC, TL432C, TL432AC	0	70	°C
		TL431I, TL431AI, TL432I, TL432AI	-40	85	



TL431, TL431A, TL432, TL432A ADJUSTABLE PRECISION SHUNT REGULATORS

SLVS005W – JULY 1978 – REVISED DECEMBER 2003

electrical characteristics over recommended operating conditions, $T_A = 25^\circ\text{C}$ (unless otherwise noted)

PARAMETER	TEST CIRCUIT	TEST CONDITIONS	TL431C, TL432C			UNIT
			MIN	TYP	MAX	
V_{ref} Reference voltage	2	$V_{\text{KA}} = V_{\text{ref}}, I_{\text{KA}} = 10 \text{ mA}$	2440	2495	2550	mV
$V_{\text{I(dev)}}$ Deviation of reference voltage over full temperature range (see Figure 1)	2	$V_{\text{KA}} = V_{\text{ref}}, I_{\text{KA}} = 10 \text{ mA}, T_A = 0^\circ\text{C to } 70^\circ\text{C}$		4	25	mV
$\frac{\Delta V_{\text{ref}}}{\Delta V_{\text{KA}}}$ Ratio of change in reference voltage to the change in cathode voltage	3	$I_{\text{KA}} = 10 \text{ mA}$	$\Delta V_{\text{KA}} = 10 \text{ V} - V_{\text{ref}}$	-1.4	-2.7	$\frac{\text{mV}}{\text{V}}$
			$\Delta V_{\text{KA}} = 36 \text{ V} - 10 \text{ V}$	-1	-2	
I_{ref} Reference current	3	$I_{\text{KA}} = 10 \text{ mA}, R_1 = 10 \text{ k}\Omega, R_2 = \infty$		2	4	μA
$I_{\text{I(dev)}}$ Deviation of reference current over full temperature range (see Figure 1)	3	$I_{\text{KA}} = 10 \text{ mA}, R_1 = 10 \text{ k}\Omega, R_2 = \infty, T_A = 0^\circ\text{C to } 70^\circ\text{C}$		0.4	1.2	μA
I_{min} Minimum cathode current for regulation	2	$V_{\text{KA}} = V_{\text{ref}}$		0.4	1	mA
I_{off} Off-state cathode current	4	$V_{\text{KA}} = 36 \text{ V}, V_{\text{ref}} = 0$		0.1	1	μA
$ z_{\text{KA}} $ Dynamic impedance (see Figure 1)	1	$I_{\text{KA}} = 1 \text{ mA to } 100 \text{ mA}, V_{\text{KA}} = V_{\text{ref}}, f \leq 1 \text{ kHz}$		0.2	0.5	Ω

The deviation parameters $V_{\text{ref(dev)}}$ and $I_{\text{ref(dev)}}$ are defined as the differences between the maximum and minimum values obtained over the recommended temperature range. The average full-range temperature coefficient of the reference voltage, $\alpha_{V_{\text{ref}}}$, is defined as:

$$|\alpha_{V_{\text{ref}}}| \left(\frac{\text{ppm}}{^\circ\text{C}} \right) = \frac{\left(\frac{V_{\text{I(dev)}}}{V_{\text{ref at } 25^\circ\text{C}}} \right) \times 10^6}{\Delta T_A}$$

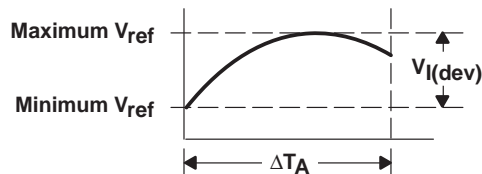

where:

ΔT_A is the recommended operating free-air temperature range of the device.

$\alpha_{V_{\text{ref}}}$ can be positive or negative, depending on whether minimum V_{ref} or maximum V_{ref} , respectively, occurs at the lower temperature.

Example: maximum $V_{\text{ref}} = 2496 \text{ mV}$ at 30°C , minimum $V_{\text{ref}} = 2492 \text{ mV}$ at 0°C , $V_{\text{ref}} = 2495 \text{ mV}$ at 25°C , $\Delta T_A = 70^\circ\text{C}$ for TL431C

$$|\alpha_{V_{\text{ref}}}| = \frac{\left(\frac{4 \text{ mV}}{2495 \text{ mV}} \right) \times 10^6}{70^\circ\text{C}} \approx 23 \text{ ppm}/^\circ\text{C}$$

Because minimum V_{ref} occurs at the lower temperature, the coefficient is positive.

Calculating Dynamic Impedance

The dynamic impedance is defined as: $|z_{\text{KA}}| = \frac{\Delta V_{\text{KA}}}{\Delta I_{\text{KA}}}$

When the device is operating with two external resistors (see Figure 3), the total dynamic impedance of the circuit is given by:

$$|z'| = \frac{\Delta V}{\Delta I} \approx |z_{\text{KA}}| \left(1 + \frac{R_1}{R_2} \right)$$

Figure 1. Calculating Deviation Parameters and Dynamic Impedance

TL431, TL431A, TL432, TL432A ADJUSTABLE PRECISION SHUNT REGULATORS

SLVS005W – JULY 1978 – REVISED DECEMBER 2003

electrical characteristics over recommended operating conditions, $T_A = 25^\circ\text{C}$ (unless otherwise noted)

PARAMETER	TEST CIRCUIT	TEST CONDITIONS	TL431I, TL432I			UNIT
			MIN	TYP	MAX	
V_{ref} Reference voltage	2	$V_{\text{KA}} = V_{\text{ref}}, I_{\text{KA}} = 10 \text{ mA}$	2440	2495	2550	mV
$V_{\text{I(dev)}}$ Deviation of reference voltage over full temperature range (see Figure 1)	2	$V_{\text{KA}} = V_{\text{ref}}, I_{\text{KA}} = 10 \text{ mA}, T_A = -40^\circ\text{C to } 85^\circ\text{C}$		5	50	mV
$\frac{\Delta V_{\text{ref}}}{\Delta V_{\text{KA}}}$ Ratio of change in reference voltage to the change in cathode voltage	3	$I_{\text{KA}} = 10 \text{ mA}$	$\Delta V_{\text{KA}} = 10 \text{ V} - V_{\text{ref}}$	-1.4	-2.7	$\frac{\text{mV}}{\text{V}}$
			$\Delta V_{\text{KA}} = 36 \text{ V} - 10 \text{ V}$	-1	-2	
I_{ref} Reference current	3	$I_{\text{KA}} = 10 \text{ mA}, R_1 = 10 \text{ k}\Omega, R_2 = \infty$		2	4	μA
$I_{\text{I(dev)}}$ Deviation of reference current over full temperature range (see Figure 1)	3	$I_{\text{KA}} = 10 \text{ mA}, R_1 = 10 \text{ k}\Omega, R_2 = \infty, T_A = -40^\circ\text{C to } 85^\circ\text{C}$		0.8	2.5	μA
I_{min} Minimum cathode current for regulation	2	$V_{\text{KA}} = V_{\text{ref}}$		0.4	1	mA
I_{off} Off-state cathode current	4	$V_{\text{KA}} = 36 \text{ V}, V_{\text{ref}} = 0$		0.1	1	μA
$ z_{\text{KA}} $ Dynamic impedance (see Figure 1)	2	$I_{\text{KA}} = 1 \text{ mA to } 100 \text{ mA}, V_{\text{KA}} = V_{\text{ref}}, f \leq 1 \text{ kHz}$		0.2	0.5	Ω

electrical characteristics over recommended operating conditions, $T_A = 25^\circ\text{C}$ (unless otherwise noted)

PARAMETER	TEST CIRCUIT	TEST CONDITIONS	TL431AC, TL432AC			UNIT
			MIN	TYP	MAX	
V_{ref} Reference voltage	2	$V_{\text{KA}} = V_{\text{ref}}, I_{\text{KA}} = 10 \text{ mA}$	2470	2495	2520	mV
$V_{\text{I(dev)}}$ Deviation of reference voltage over full temperature range (see Figure 1)	2	$V_{\text{KA}} = V_{\text{ref}}, I_{\text{KA}} = 10 \text{ mA}, T_A = 0^\circ\text{C to } 70^\circ\text{C}$		4	25	mV
$\frac{\Delta V_{\text{ref}}}{\Delta V_{\text{KA}}}$ Ratio of change in reference voltage to the change in cathode voltage	3	$I_{\text{KA}} = 10 \text{ mA}$	$\Delta V_{\text{KA}} = 10 \text{ V} - V_{\text{ref}}$	-1.4	-2.7	$\frac{\text{mV}}{\text{V}}$
			$\Delta V_{\text{KA}} = 36 \text{ V} - 10 \text{ V}$	-1	-2	
I_{ref} Reference current	3	$I_{\text{KA}} = 10 \text{ mA}, R_1 = 10 \text{ k}\Omega, R_2 = \infty$		2	4	μA
$I_{\text{I(dev)}}$ Deviation of reference current over full temperature range (see Figure 1)	3	$I_{\text{KA}} = 10 \text{ mA}, R_1 = 10 \text{ k}\Omega, R_2 = \infty, T_A = 0^\circ\text{C to } 70^\circ\text{C}$		0.8	1.2	μA
I_{min} Minimum cathode current for regulation	2	$V_{\text{KA}} = V_{\text{ref}}$		0.4	0.6	mA
I_{off} Off-state cathode current	4	$V_{\text{KA}} = 36 \text{ V}, V_{\text{ref}} = 0$		0.1	0.5	μA
$ z_{\text{KA}} $ Dynamic impedance (see Figure 1)	1	$I_{\text{KA}} = 1 \text{ mA to } 100 \text{ mA}, V_{\text{KA}} = V_{\text{ref}}, f \leq 1 \text{ kHz}$		0.2	0.5	Ω



TL431, TL431A, TL432, TL432A

ADJUSTABLE PRECISION SHUNT REGULATORS

SLVS005W – JULY 1978 – REVISED DECEMBER 2003

electrical characteristics over recommended operating conditions, $T_A = 25^\circ\text{C}$ (unless otherwise noted)

PARAMETER	TEST CIRCUIT	TEST CONDITIONS	TL431AI, TL432AI			UNIT
			MIN	TYP	MAX	
V_{ref} Reference voltage	2	$V_{\text{KA}} = V_{\text{ref}}, I_{\text{KA}} = 10 \text{ mA}$	2470	2495	2520	mV
$V_{\text{I(dev)}}$ Deviation of reference voltage over full temperature range (see Figure 1)	2	$V_{\text{KA}} = V_{\text{ref}}, I_{\text{KA}} = 10 \text{ mA}, T_A = -40^\circ\text{C} \text{ to } 85^\circ\text{C}$		5	50	mV
$\frac{\Delta V_{\text{ref}}}{\Delta V_{\text{KA}}}$ Ratio of change in reference voltage to the change in cathode voltage	3	$I_{\text{KA}} = 10 \text{ mA}$	$\Delta V_{\text{KA}} = 10 \text{ V} - V_{\text{ref}}$	-1.4	-2.7	$\frac{\text{mV}}{\text{V}}$
			$\Delta V_{\text{KA}} = 36 \text{ V} - 10 \text{ V}$	-1	-2	
I_{ref} Reference current	3	$I_{\text{KA}} = 10 \text{ mA}, R1 = 10 \text{ k}\Omega, R2 = \infty$		2	4	μA
$I_{\text{I(dev)}}$ Deviation of reference current over full temperature range (see Figure 1)	3	$I_{\text{KA}} = 10 \text{ mA}, R1 = 10 \text{ k}\Omega, R2 = \infty, T_A = -40^\circ\text{C} \text{ to } 85^\circ\text{C}$		0.8	2.5	μA
I_{min} Minimum cathode current for regulation	2	$V_{\text{KA}} = V_{\text{ref}}$		0.4	0.7	mA
I_{off} Off-state cathode current	4	$V_{\text{KA}} = 36 \text{ V}, V_{\text{ref}} = 0$		0.1	0.5	μA
$ z_{\text{KA}} $ Dynamic impedance (see Figure 1)	2	$I_{\text{KA}} = 1 \text{ mA} \text{ to } 100 \text{ mA}, V_{\text{KA}} = V_{\text{ref}}, f \leq 1 \text{ kHz}$		0.2	0.5	Ω

PARAMETER MEASUREMENT INFORMATION

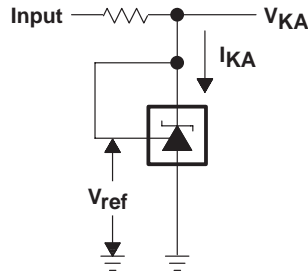

Figure 2. Test Circuit for $V_{KA} = V_{ref}$

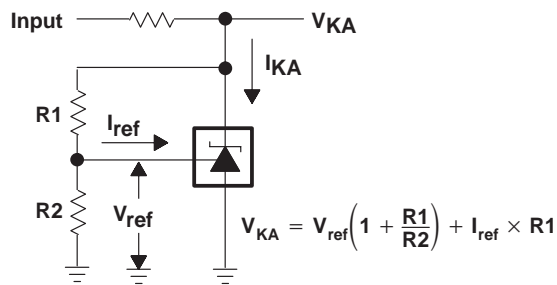

Figure 3. Test Circuit for $V_{KA} > V_{ref}$

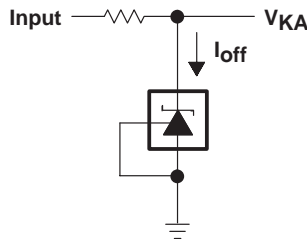

Figure 4. Test Circuit for I_{off}

TL431, TL431A, TL432, TL432A ADJUSTABLE PRECISION SHUNT REGULATORS

SLVS005W – JULY 1978 – REVISED DECEMBER 2003

TYPICAL CHARACTERISTICS

Table 1. Graphs

	FIGURE
Reference input voltage vs Free-air temperature	5
Reference input current vs Free-air temperature	6
Cathode current vs Cathode voltage	7, 8
Off-state cathode current vs Free-air temperature	9
Ratio of delta reference voltage to change in cathode voltage vs Free-air temperature	10
Equivalent input noise voltage vs Frequency	11
Equivalent input noise voltage over a 10-second period	12
Small-signal voltage amplification vs Frequency	13
Reference impedance vs Frequency	14
Pulse response	15
Stability boundary conditions	16

Table 2. Application Circuits

	FIGURE
Shunt regulator	17
Single-supply comparator with temperature-compensated threshold	18
Precision high-current series regulator	19
Output control of a three-terminal fixed regulator	20
High-current shunt regulator	21
Crowbar circuit	22
Precision 5-V 1.5-A regulator	23
Efficient 5-V precision regulator	24
PWM converter with reference	25
Voltage monitor	26
Delay timer	27
Precision current limiter	28
Precision constant-current sink	29

TYPICAL CHARACTERISTICS†

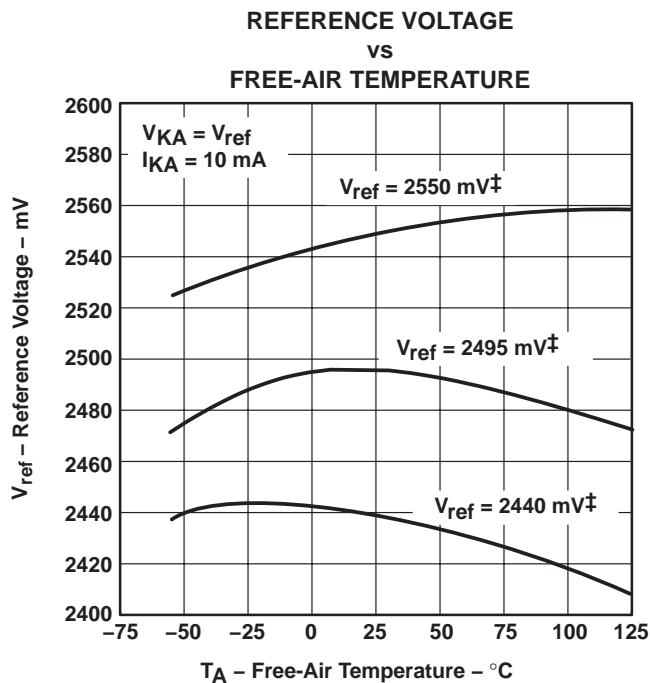

† Data is for devices having the indicated value of V_{ref} at $I_{KA} = 10 \text{ mA}$, $T_A = 25^\circ\text{C}$.

Figure 5

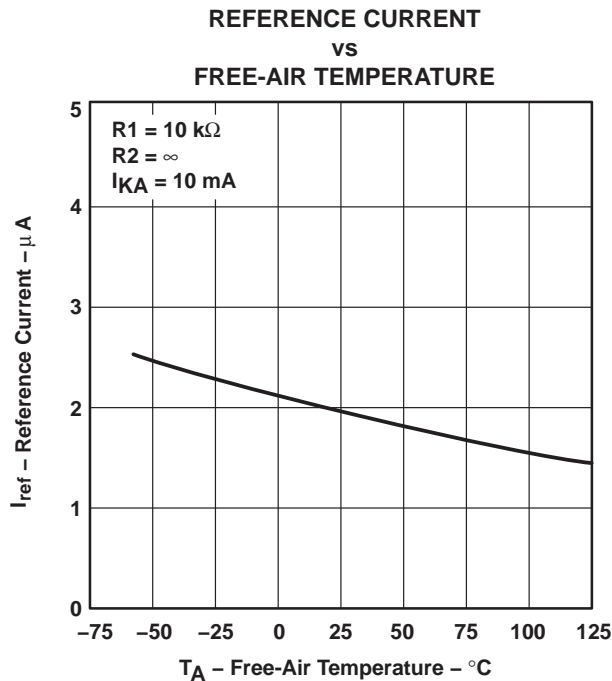

Figure 6

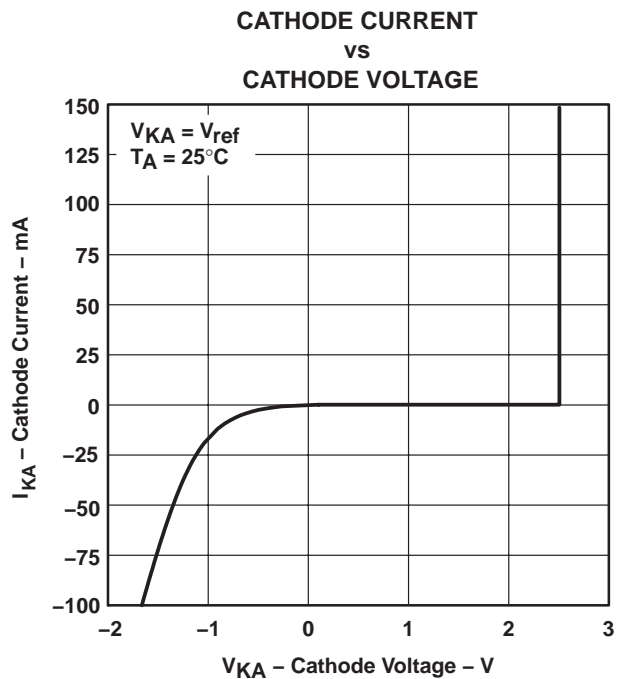

Figure 7

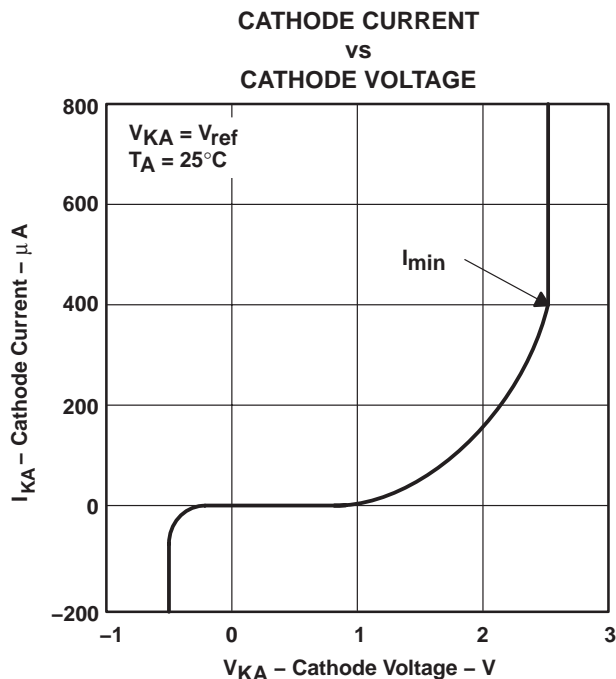

Figure 8

† Data at high and low temperatures is applicable only within the recommended operating free-air temperature ranges of the various devices.

TL431, TL431A, TL432, TL432A ADJUSTABLE PRECISION SHUNT REGULATORS

SLVS005W – JULY 1978 – REVISED DECEMBER 2003

TYPICAL CHARACTERISTICS†

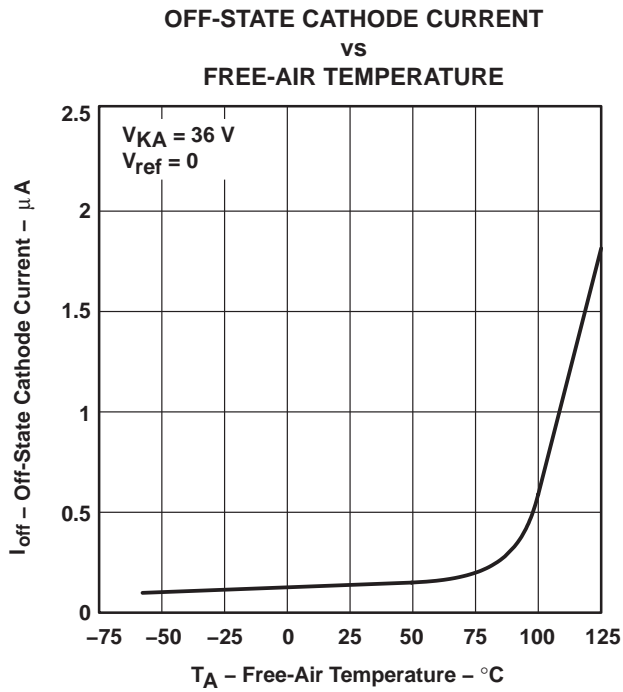

Figure 9

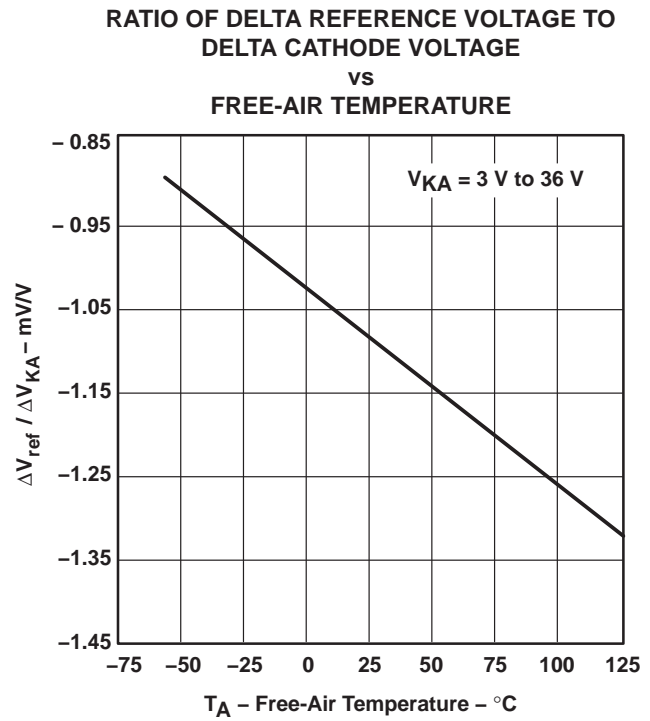

Figure 10

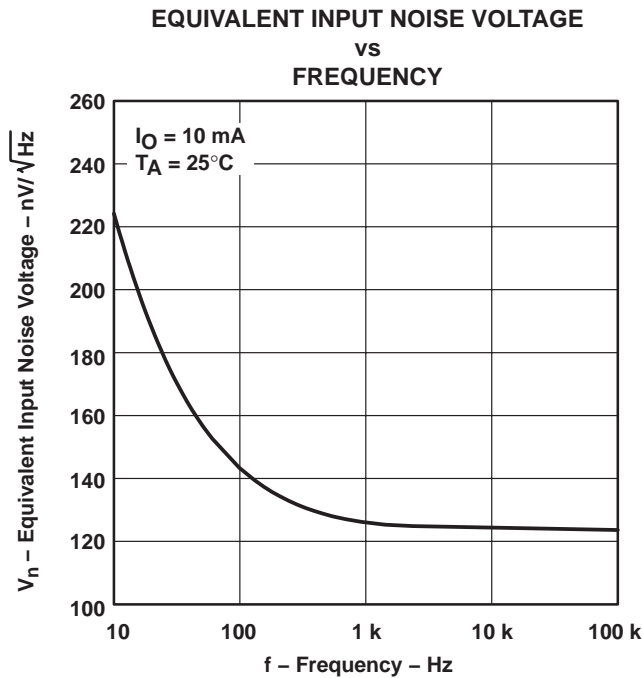

Figure 11

† Data at high and low temperatures is applicable only within the recommended operating free-air temperature ranges of the various devices.

TYPICAL CHARACTERISTICS

EQUIVALENT INPUT NOISE VOLTAGE
OVER A 10-SECOND PERIOD

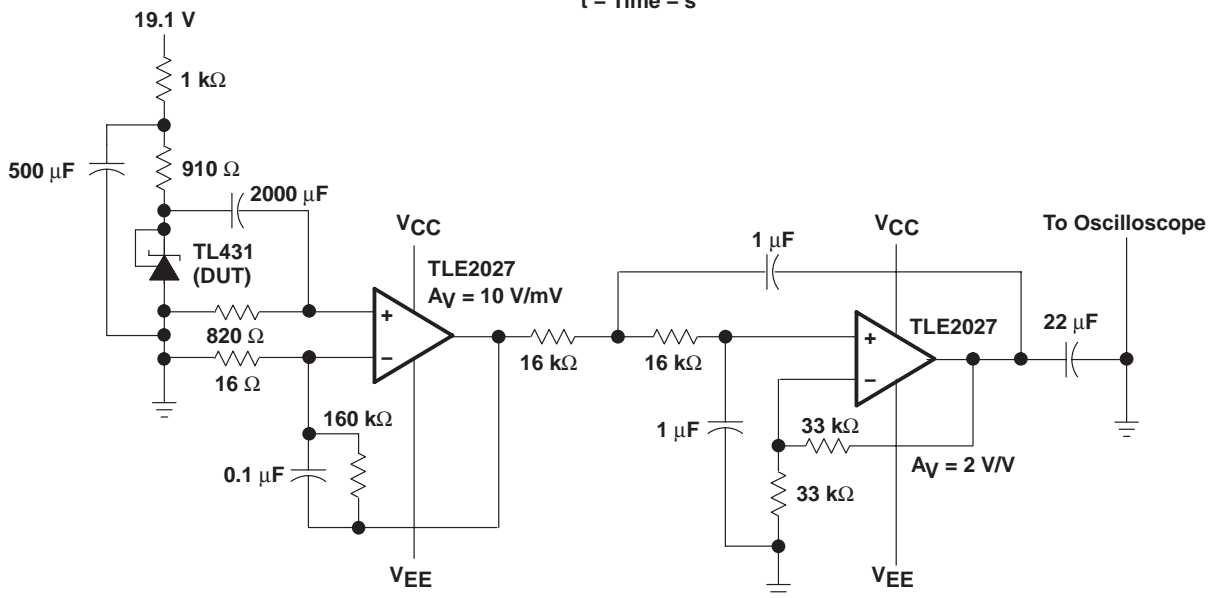
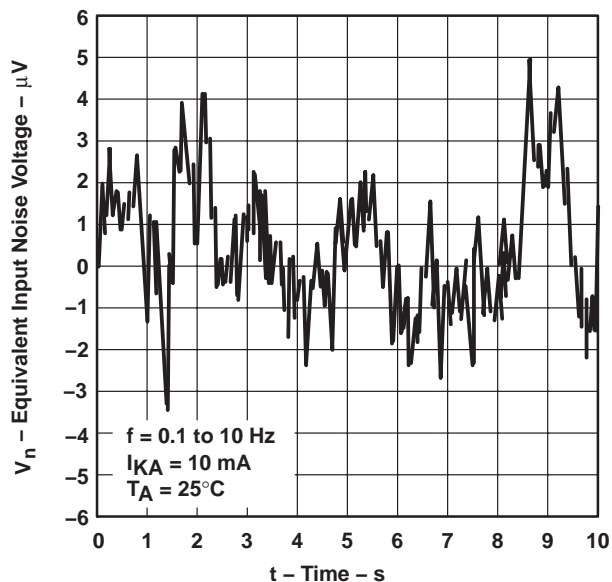

Figure 12. Test Circuit for Equivalent Input Noise Voltage

TL431, TL431A, TL432, TL432A ADJUSTABLE PRECISION SHUNT REGULATORS

SLVS005W – JULY 1978 – REVISED DECEMBER 2003

TYPICAL CHARACTERISTICS

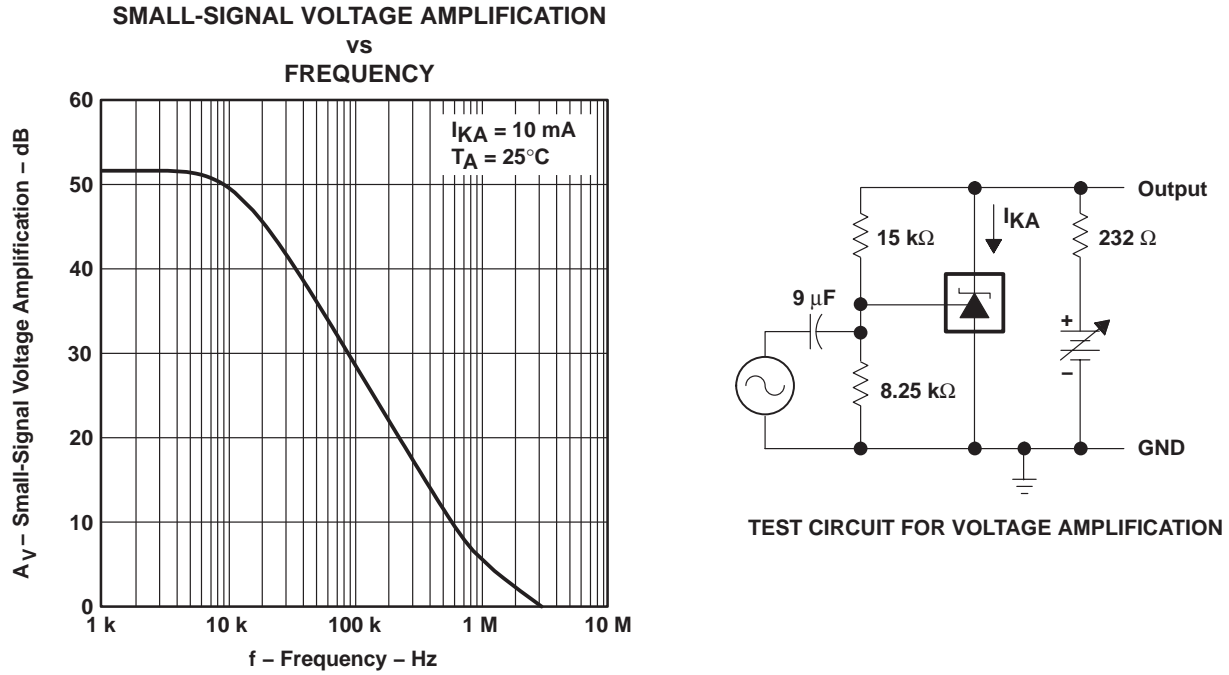

Figure 13

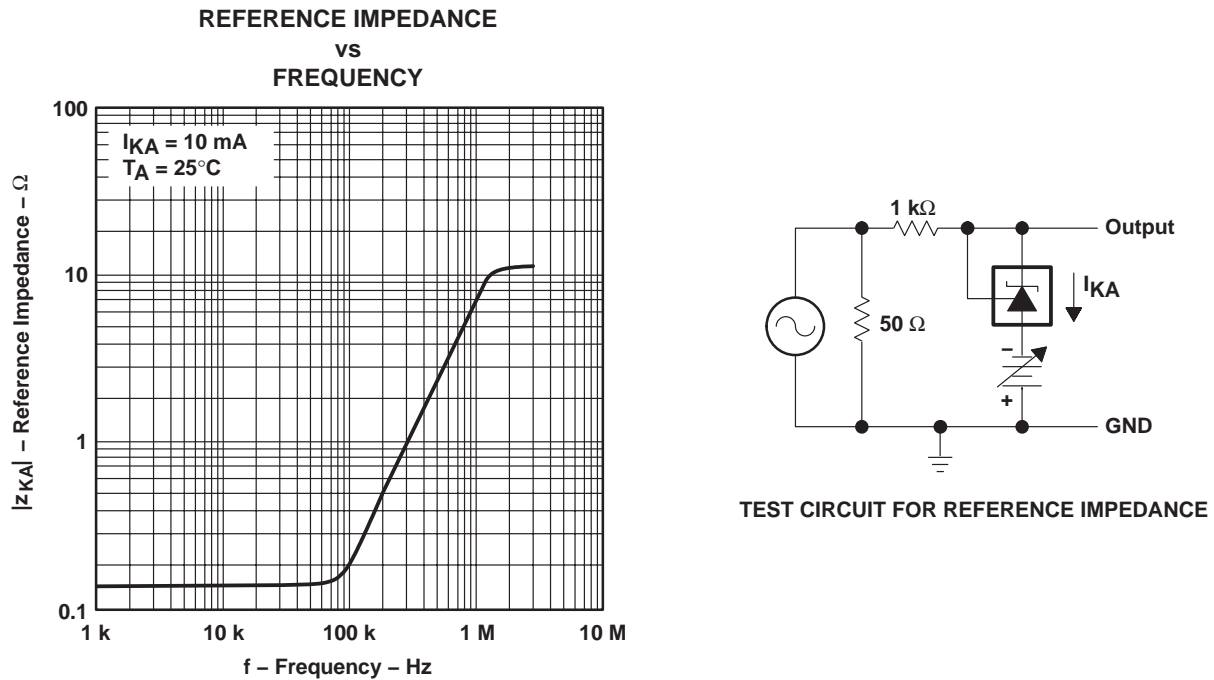

Figure 14

TYPICAL CHARACTERISTICS

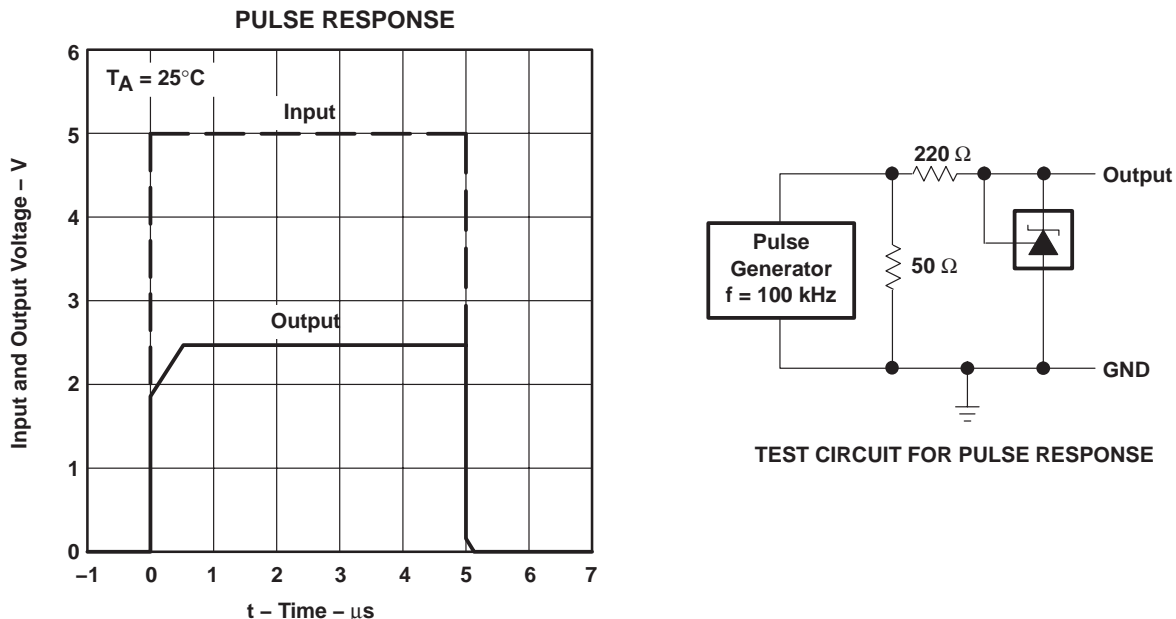

Figure 15

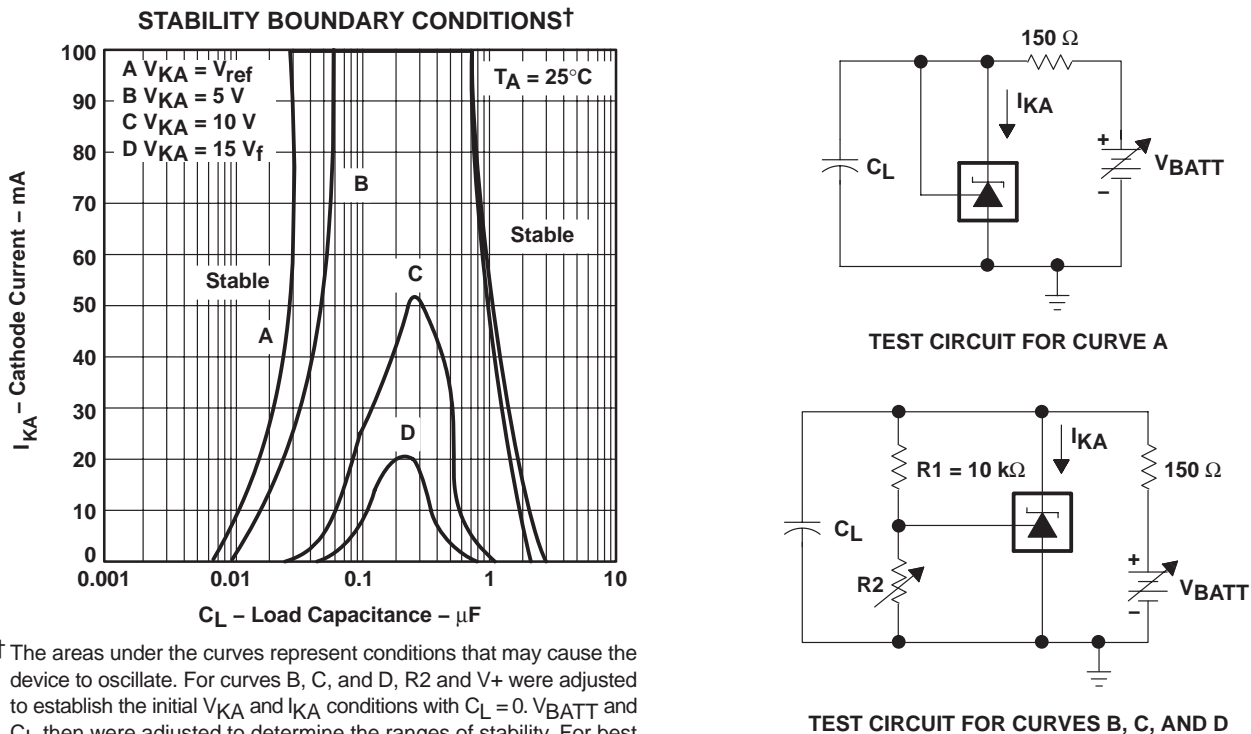
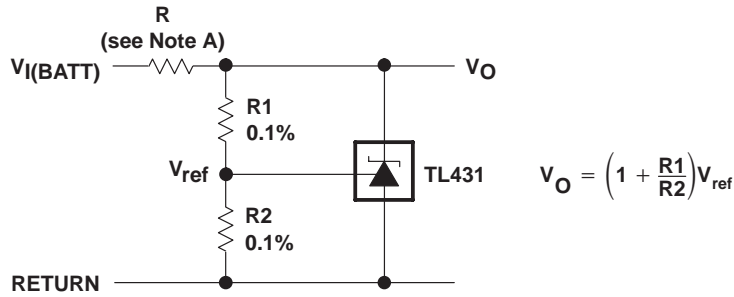

Figure 16

TL431, TL431A, TL432, TL432A ADJUSTABLE PRECISION SHUNT REGULATORS

SLVS005W – JULY 1978 – REVISED DECEMBER 2003

APPLICATION INFORMATION



NOTE A: R should provide cathode current ≥ 1 mA to the TL431 at minimum $V_{I(BATT)}$.

Figure 17. Shunt Regulator

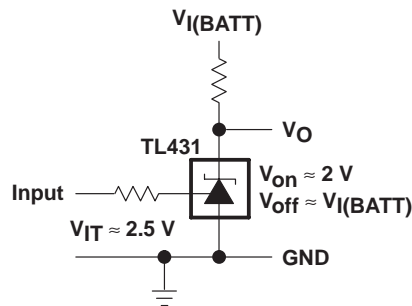
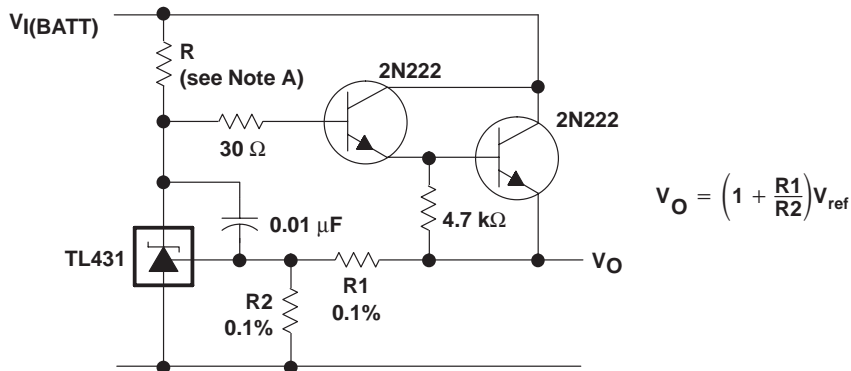

Figure 18. Single-Supply Comparator With Temperature-Compensated Threshold



NOTE A: R should provide cathode current ≥ 1 mA to the TL431 at minimum $V_{I(BATT)}$.

Figure 19. Precision High-Current Series Regulator

APPLICATION INFORMATION

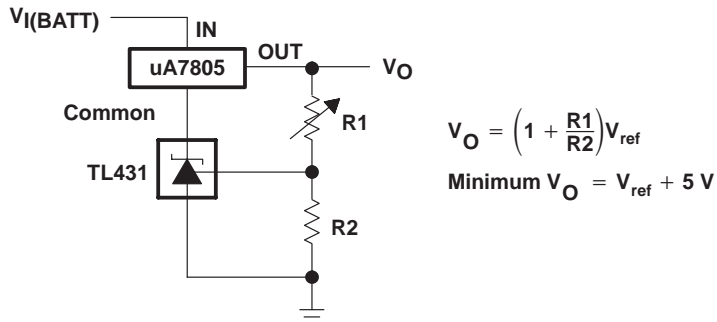

Figure 20. Output Control of a Three-Terminal Fixed Regulator

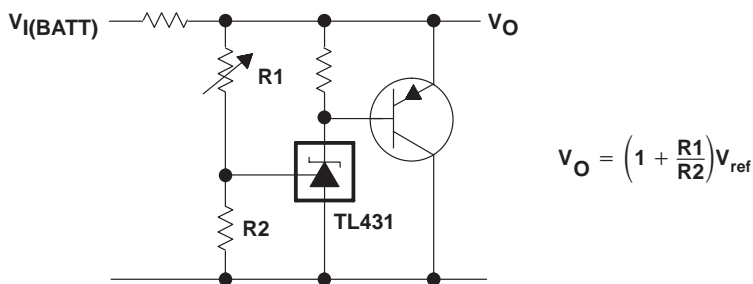
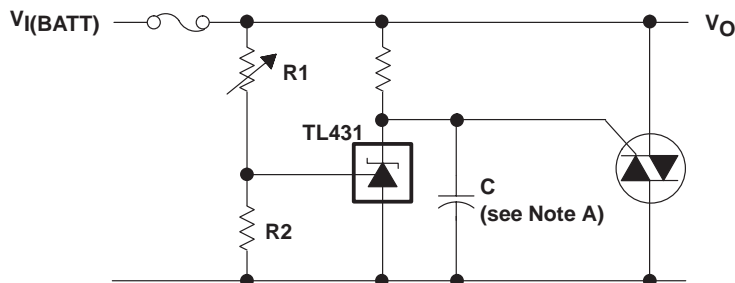

Figure 21. High-Current Shunt Regulator



NOTE A: Refer to the stability boundary conditions in Figure 16 to determine allowable values for C.

Figure 22. Crowbar Circuit

TL431, TL431A, TL432, TL432A ADJUSTABLE PRECISION SHUNT REGULATORS

SLVS005W – JULY 1978 – REVISED DECEMBER 2003

APPLICATION INFORMATION

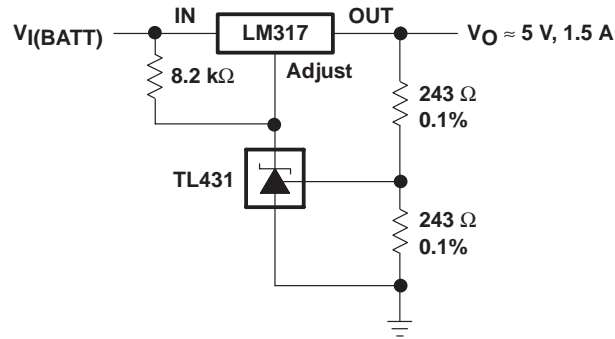
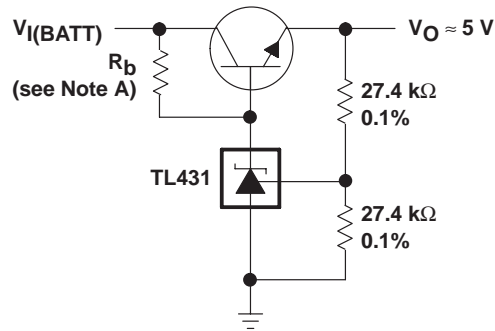

Figure 23. Precision 5-V 1.5-A Regulator



NOTE A: R_b should provide cathode current $\geq 1\text{ mA}$ to the TL431.

Figure 24. Efficient 5-V Precision Regulator

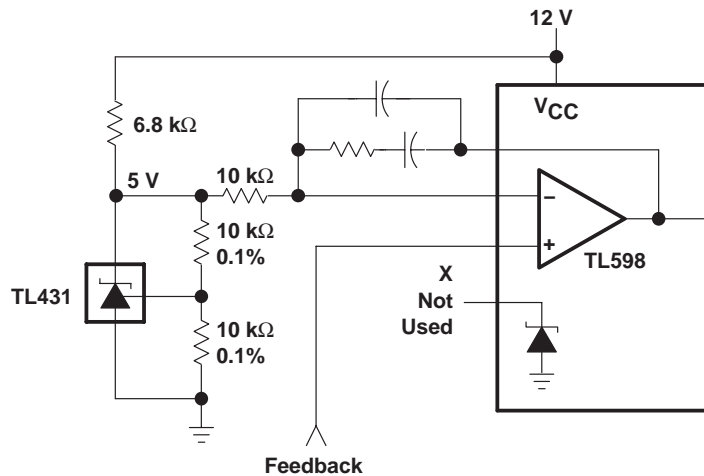
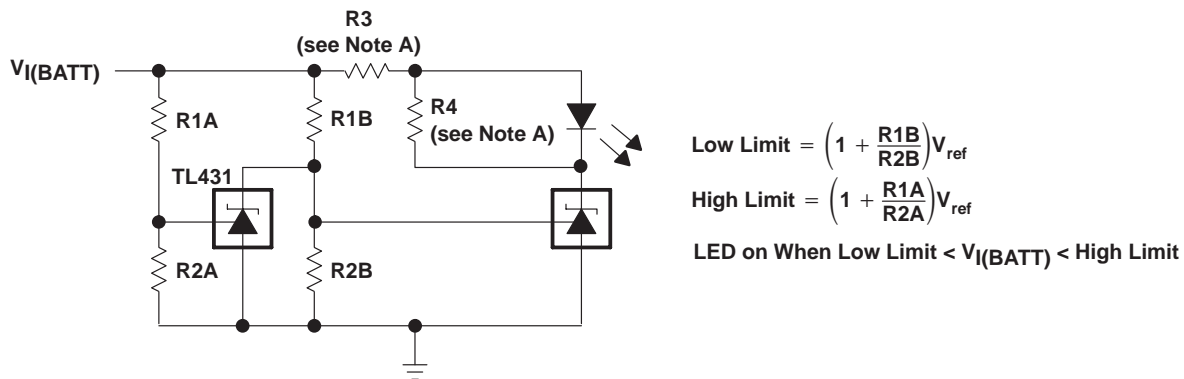

Figure 25. PWM Converter With Reference

APPLICATION INFORMATION



NOTE A: R3 and R4 are selected to provide the desired LED intensity and cathode current ≥ 1 mA to the TL431 at the available $V_{I(BATT)}$.

Figure 26. Voltage Monitor

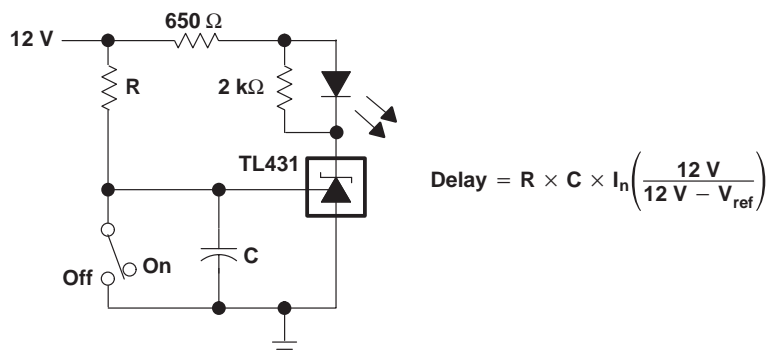

Figure 27. Delay Timer

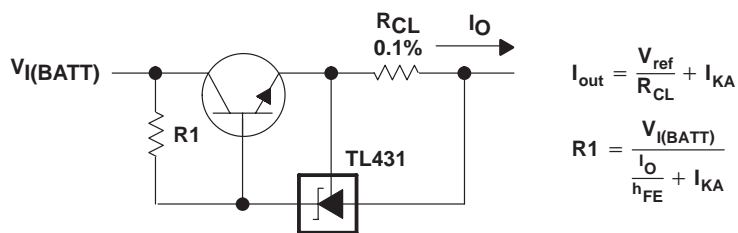

Figure 28. Precision Current Limiter

TL431, TL431A, TL432, TL432A ADJUSTABLE PRECISION SHUNT REGULATORS

SLVS005W – JULY 1978 – REVISED DECEMBER 2003

APPLICATION INFORMATION

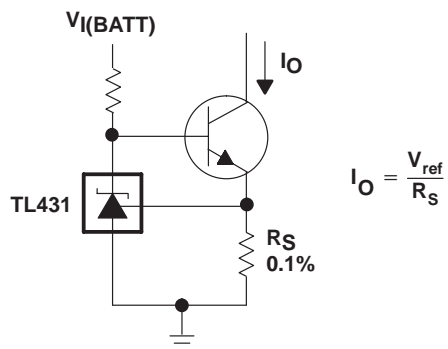

Figure 29. Precision Constant-Current Sink

JG (R-GDIP-T8)

CERAMIC DUAL-IN-LINE



- NOTES: A. All linear dimensions are in inches (millimeters).
 B. This drawing is subject to change without notice.
 C. This package can be hermetically sealed with a ceramic lid using glass frit.
 D. Index point is provided on cap for terminal identification.
 E. Falls within MIL STD 1835 GDIP1-T8

PK (R-PSSO-F3)

PLASTIC SINGLE-IN-LINE PACKAGE

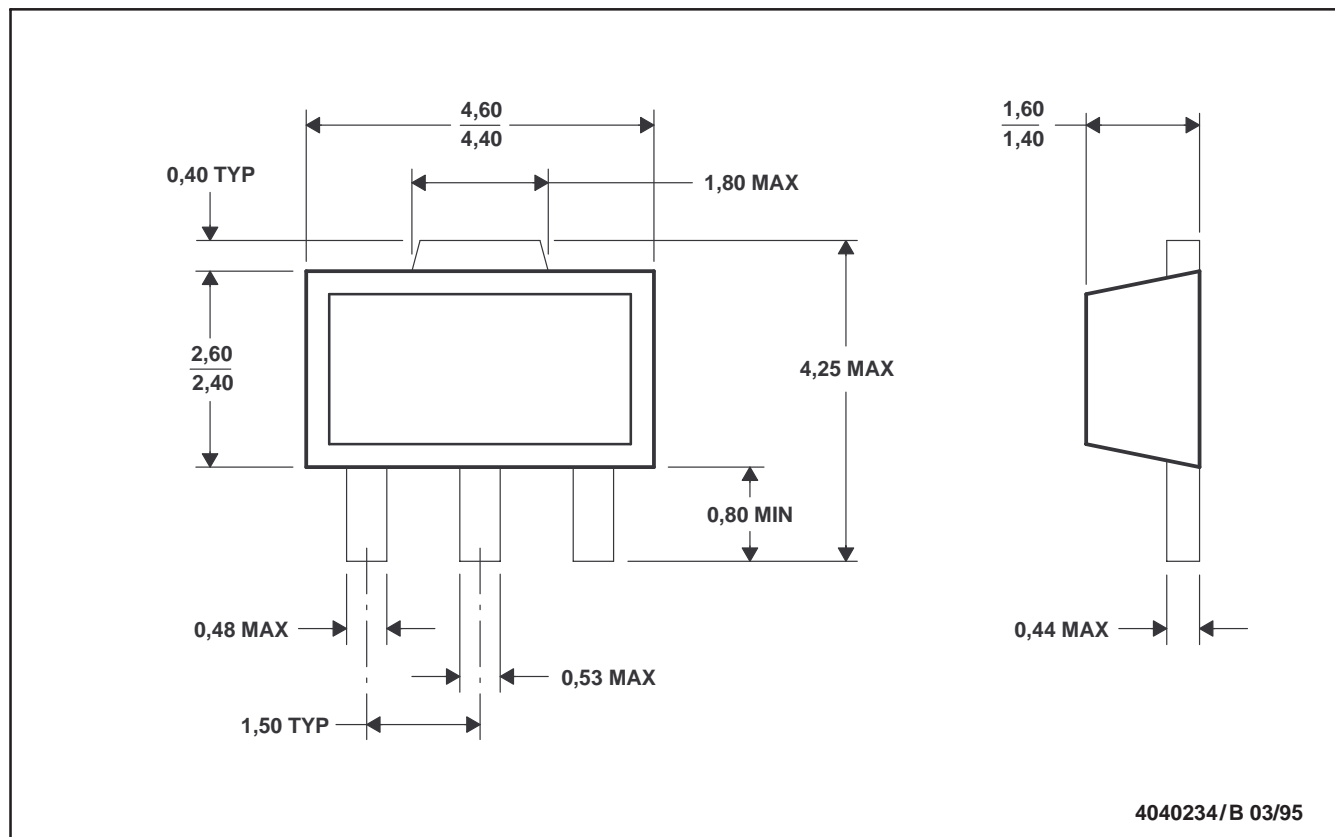

- NOTES: A. All linear dimensions are in millimeters.
B. This drawing is subject to change without notice.
C. The center lead is in electrical contact with the tab.

FK (S-CQCC-N**)

LEADLESS CERAMIC CHIP CARRIER

28 TERMINAL SHOWN



- NOTES:
- A. All linear dimensions are in inches (millimeters).
 - B. This drawing is subject to change without notice.
 - C. This package can be hermetically sealed with a metal lid.
 - D. The terminals are gold plated.
 - E. Falls within JEDEC MS-004

P (R-PDIP-T8)

PLASTIC DUAL-IN-LINE



4040082/D 05/98

- NOTES: A. All linear dimensions are in inches (millimeters).
 B. This drawing is subject to change without notice.
 C. Falls within JEDEC MS-001

For the latest package information, go to http://www.ti.com/sc/docs/package/pkg_info.htm



DBV (R-PDSO-G5)

PLASTIC SMALL-OUTLINE PACKAGE

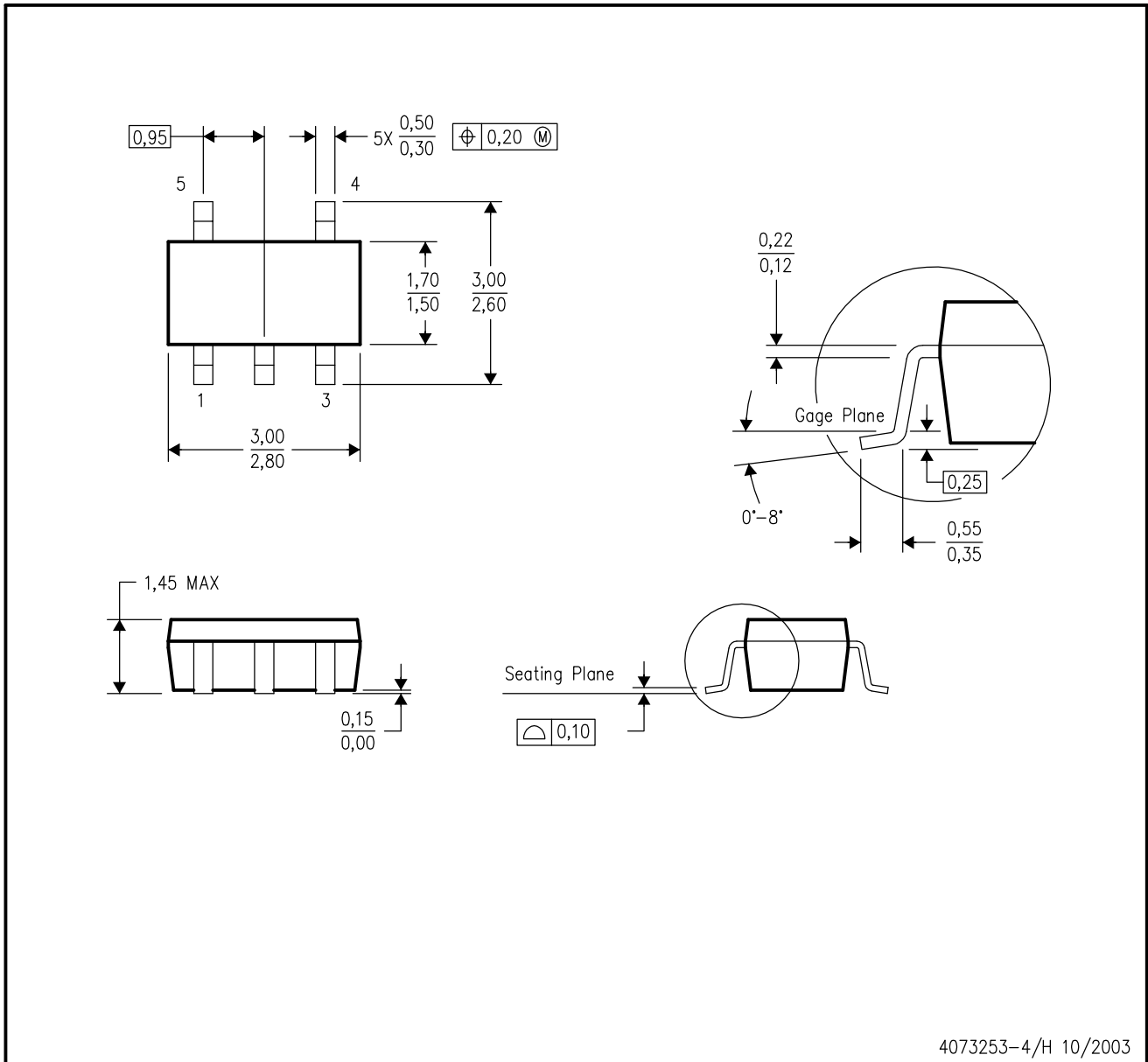

- NOTES:
- A. All linear dimensions are in millimeters.
 - B. This drawing is subject to change without notice.
 - C. Body dimensions do not include mold flash or protrusion.
 - D. Falls within JEDEC MO-178 Variation AA.

KTP (R-PSFM-G2)

PowerFLEX™ PLASTIC FLANGE-MOUNT PACKAGE

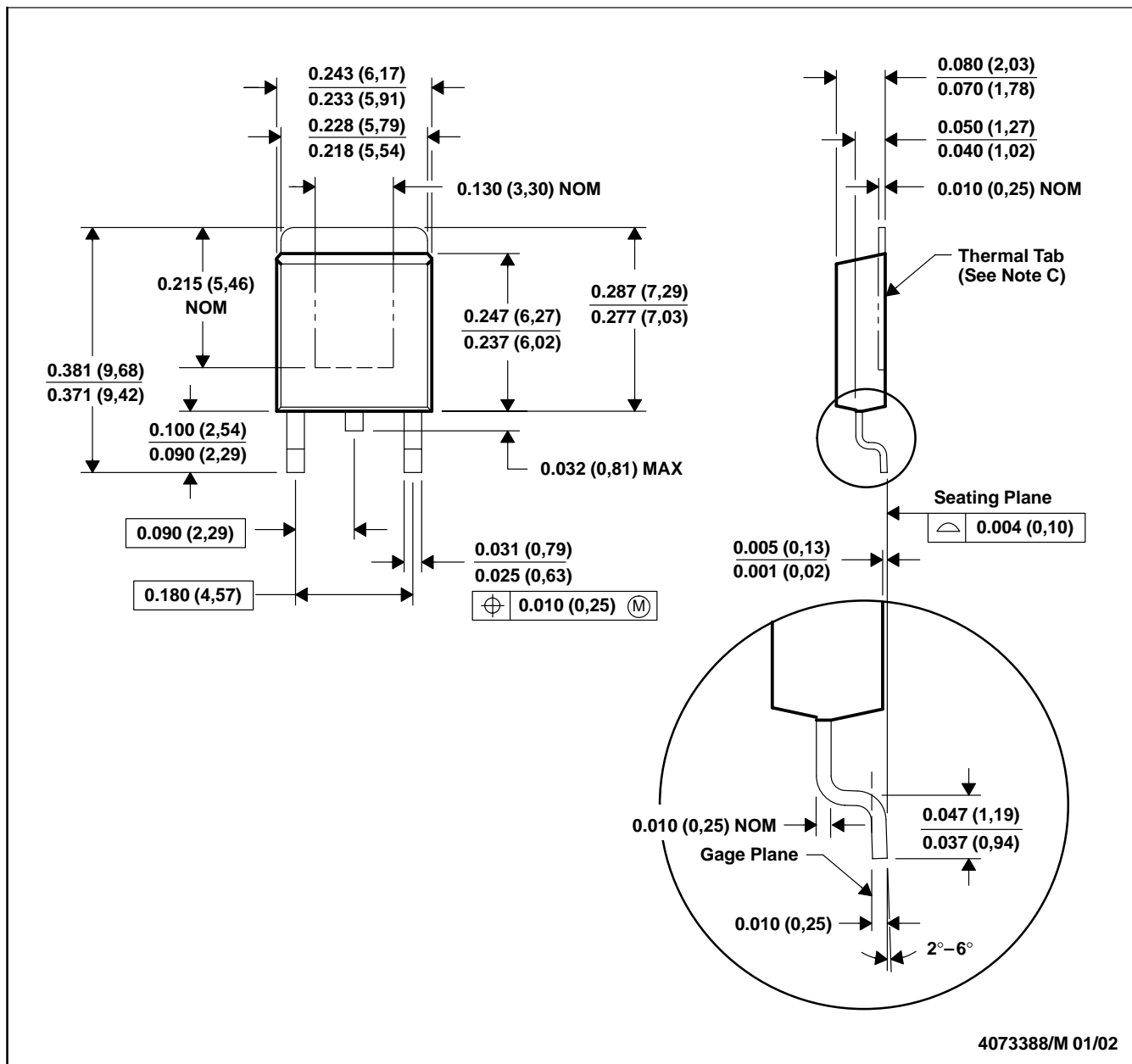

- NOTES: A. All linear dimensions are in inches (millimeters).
 B. This drawing is subject to change without notice.
 C. The center lead is in electrical contact with the thermal tab.
 D. Dimensions do not include mold protrusions, not to exceed 0.006 (0,15).
 E. Falls within JEDEC TO-252 variation AC.

PowerFLEX is a trademark of Texas Instruments.

D (R-PDSO-G**)

PLASTIC SMALL-OUTLINE PACKAGE

8 PINS SHOWN

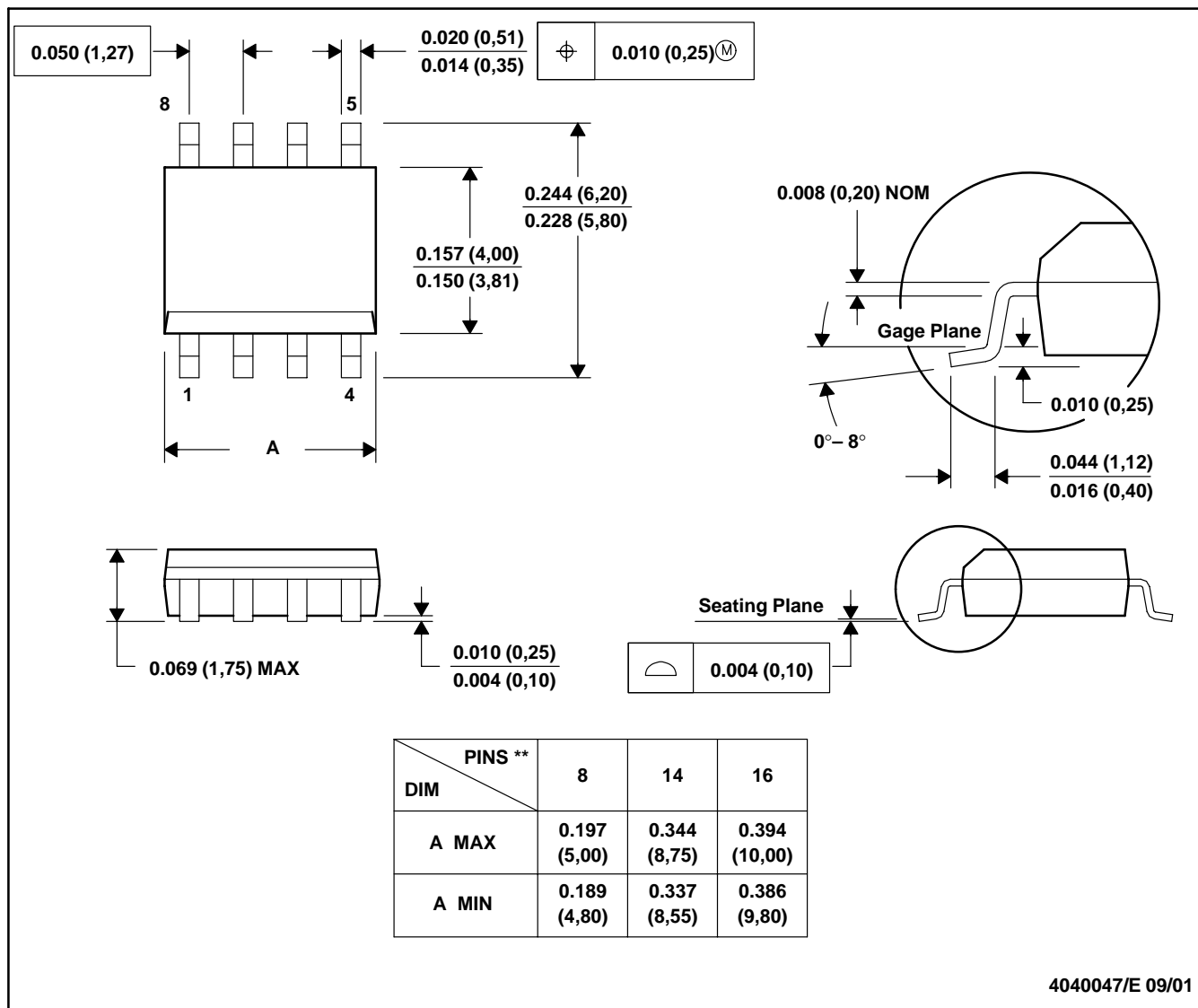

- NOTES: A. All linear dimensions are in inches (millimeters).
 B. This drawing is subject to change without notice.
 C. Body dimensions do not include mold flash or protrusion, not to exceed 0.006 (0,15).
 D. Falls within JEDEC MS-012

MECHANICAL DATA

PS (R-PDSO-G8)

PLASTIC SMALL-OUTLINE PACKAGE



- NOTES:
- A. All linear dimensions are in millimeters.
 - B. This drawing is subject to change without notice.
 - C. Body dimensions do not include mold flash or protrusion, not to exceed 0,15.

LP (O-PBCY-W3)

PLASTIC CYLINDRICAL PACKAGE

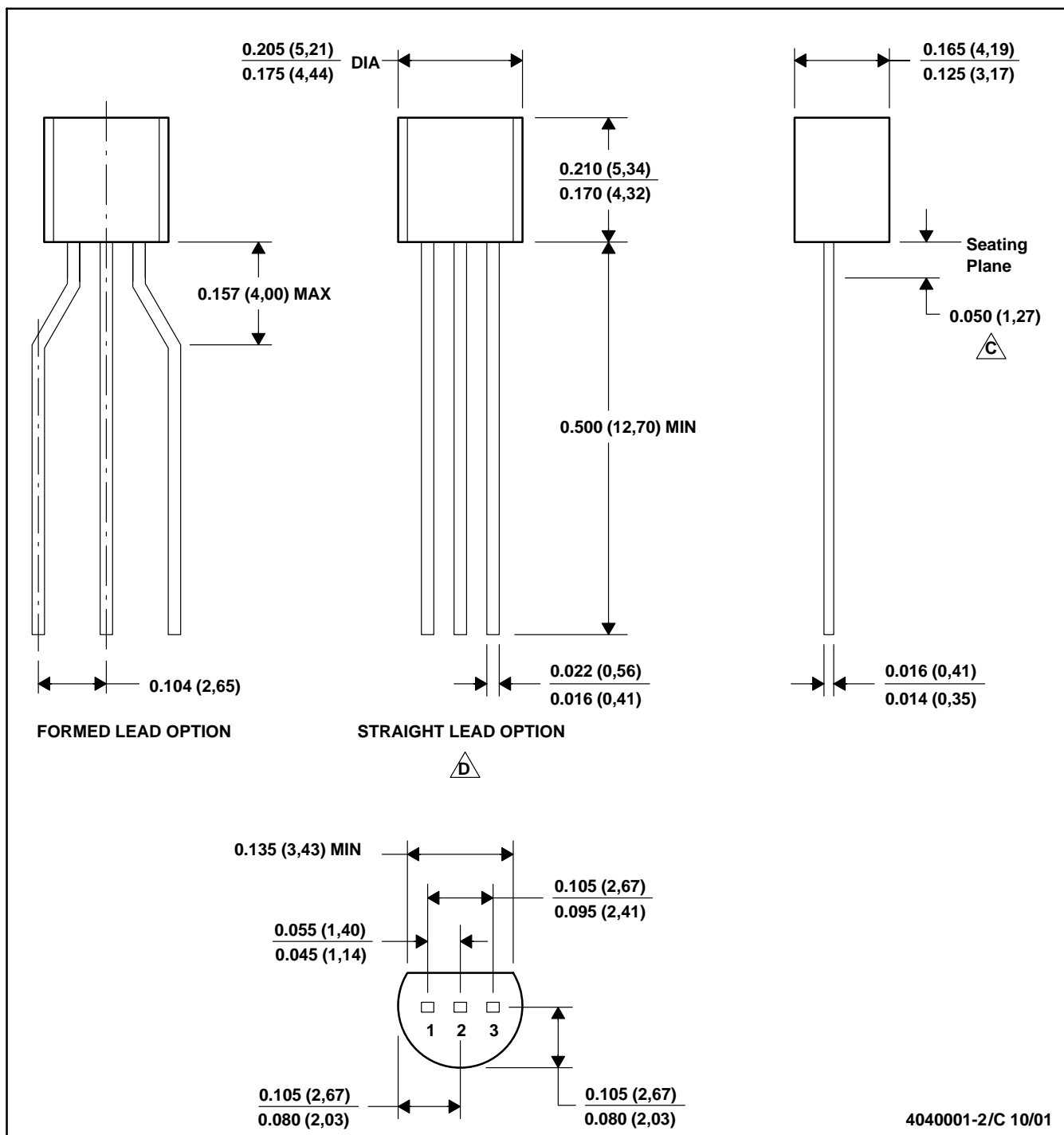

4040001-2/C 10/01

- NOTES: A. All linear dimensions are in inches (millimeters).
 B. This drawing is subject to change without notice.
C Lead dimensions are not controlled within this area
D Falls within JEDEC TO -226 Variation AA (TO-226 replaces TO-92)
 E. Shipping Method:
 Straight lead option available in bulk pack only.
 Formed lead option available in tape & reel or ammo pack.



MECHANICAL DATA

MSOT002A – OCTOBER 1994 – REVISED NOVEMBER 2001

LP (O-PBCY-W3)

PLASTIC CYLINDRICAL PACKAGE

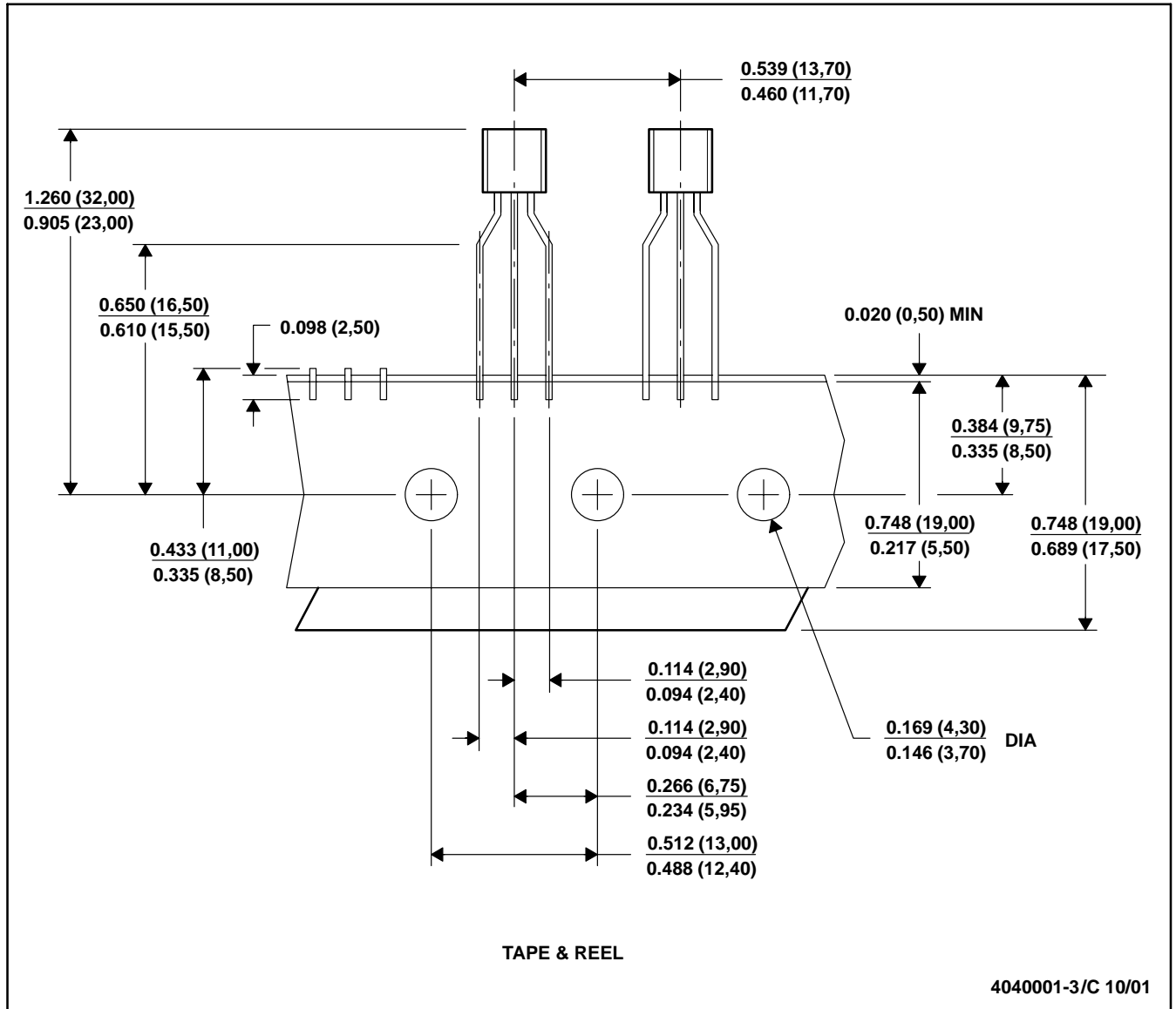

- NOTES:
- All linear dimensions are in inches (millimeters).
 - This drawing is subject to change without notice.
 - Tape and Reel information for the Format Lead Option package.

PW (R-PDSO-G**)

PLASTIC SMALL-OUTLINE PACKAGE

14 PINS SHOWN



4040064/F 01/97

- NOTES: A. All linear dimensions are in millimeters.
 B. This drawing is subject to change without notice.
 C. Body dimensions do not include mold flash or protrusion not to exceed 0,15.
 D. Falls within JEDEC MO-153

IMPORTANT NOTICE

Texas Instruments Incorporated and its subsidiaries (TI) reserve the right to make corrections, modifications, enhancements, improvements, and other changes to its products and services at any time and to discontinue any product or service without notice. Customers should obtain the latest relevant information before placing orders and should verify that such information is current and complete. All products are sold subject to TI's terms and conditions of sale supplied at the time of order acknowledgment.

TI warrants performance of its hardware products to the specifications applicable at the time of sale in accordance with TI's standard warranty. Testing and other quality control techniques are used to the extent TI deems necessary to support this warranty. Except where mandated by government requirements, testing of all parameters of each product is not necessarily performed.

TI assumes no liability for applications assistance or customer product design. Customers are responsible for their products and applications using TI components. To minimize the risks associated with customer products and applications, customers should provide adequate design and operating safeguards.

TI does not warrant or represent that any license, either express or implied, is granted under any TI patent right, copyright, mask work right, or other TI intellectual property right relating to any combination, machine, or process in which TI products or services are used. Information published by TI regarding third-party products or services does not constitute a license from TI to use such products or services or a warranty or endorsement thereof. Use of such information may require a license from a third party under the patents or other intellectual property of the third party, or a license from TI under the patents or other intellectual property of TI.

Reproduction of information in TI data books or data sheets is permissible only if reproduction is without alteration and is accompanied by all associated warranties, conditions, limitations, and notices. Reproduction of this information with alteration is an unfair and deceptive business practice. TI is not responsible or liable for such altered documentation.

Resale of TI products or services with statements different from or beyond the parameters stated by TI for that product or service voids all express and any implied warranties for the associated TI product or service and is an unfair and deceptive business practice. TI is not responsible or liable for any such statements.

Following are URLs where you can obtain information on other Texas Instruments products and application solutions:

Products		Applications	
Amplifiers	amplifier.ti.com	Audio	www.ti.com/audio
Data Converters	dataconverter.ti.com	Automotive	www.ti.com/automotive
DSP	dsp.ti.com	Broadband	www.ti.com/broadband
Interface	interface.ti.com	Digital Control	www.ti.com/digitalcontrol
Logic	logic.ti.com	Military	www.ti.com/military
Power Mgmt	power.ti.com	Optical Networking	www.ti.com/opticalnetwork
Microcontrollers	microcontroller.ti.com	Security	www.ti.com/security
		Telephony	www.ti.com/telephony
		Video & Imaging	www.ti.com/video
		Wireless	www.ti.com/wireless

Mailing Address: Texas Instruments
Post Office Box 655303 Dallas, Texas 75265

Copyright © 2003, Texas Instruments Incorporated